

HEATSTRIP[®]

R A D I A N T O U T D O O R H E A T E R S



Product & Installation Manual



HEATSTRIP[®] Classic (THH-A)

The heater that is a design feature!





Product Overview

Rev I MAR16

There are three (3) different series of products within the Heatstrip® product category. Each has a different temperature output, making them ideal for different applications. Below is a list of some common applications to assist with the selection of the most effective and efficient series.

HEATSTRIP® Classic (THH-A models) is a premium high temperature heater and is primarily used for outdoor rooms where there is 1,2 3, or 4 enclosed sides, with an mounting height of 2.1m to 2.7m.

HEATSTRIP® Max (THX models) is an ultra high temperature heater used for uncovered or open indoor or outdoor areas with a mounting height of 2.1 m to 3.0m.

HEATSTRIP® Indoor (THS-A models) is a medium intensity heater used for protected indoor applications only.

APPLICATION	THS	THH	THX
Indoor insulated areas, classrooms, offices, bathrooms, wet areas, drying rooms	√	√	
Outdoor under cover, café, veranda, patio, balcony ceiling height 2.7m or less		√	√
Outdoor under cover, café, veranda, patio, balcony ceiling height 2.7m to 3.0m			√
Highly exposed outdoor area			√
Indoor open area, warehouse, factory, production areas, sports facilities	√	√	√
Indoor spot heating, above tables, assembly areas		√	√



Heatstrip Indoor (THS-A)



Heatstrip Classic (THH-A)



Heatstrip Max (THX)



Efficient, cost effective electric heating

The innovative design of the HEATSTRIP® enables comfortable and even heat dispersion from the surface with minimal operating costs.

Design flexibility

Four HEATSTRIP® models are available, ensuring the heating requirements of any undercover outdoor or open indoor area is possible. Brackets for direct ceiling or wall/ceiling angled mounting are supplied as standard. Optional HEATSTRIP® accessories include beam or fixed umbrella mount brackets, extension mount brackets, chain suspension brackets, twin mount brackets and flush mounting enclosures.

Minimal maintenance

The HEATSTRIP® incorporates no internal moving parts ensuring quiet and virtually maintenance free operation.

Australian made

Designed, engineered and assembled in Australia the HEATSTRIP®, is fully backed by a 24 month residential warranty, and 12 month commercial warranty.

Stylish design— *The Heater that is a Design Feature!*

The attractive HEATSTRIP® comes with a standard black face and anodised alloy rear casing.

Easy to use

The standard HEATSTRIP® is controller by a simple on/off operation, either when plugged directly into a power point, or hard-wired via a wall mounted on/off switch. The unit takes approximately 15 minutes to heat up to maximum temperature and approximately 30 minutes to cool down, depending upon the ambient temperature. Please don't forget to turn it off. We recommend installing your HEATSTRIP® Classic with a timer controller to ensure the unit is turned off after a preset time. Thermofilm recommends Model TT-MTM controller, which includes a timer function and temperature control.





Why choose Heatstrip® electric radiant heaters for your outdoor or hard-to-heat indoor area?

Many conventional patio heaters rely on convection heating which works by heating the surrounding air to provide comfort. This can be quite impractical for outdoor and open-indoor areas as there is typically constant air movement which can easily blow away the warmed air. Radiant style heaters transfer heat directly to objects through infra-red waves. While convection heaters heat the air between objects, radiant heaters directly heat the surface of the objects themselves. HEATSTRIP® electric radiant heaters are more effective within an outdoor or uninsulated indoor area because they provide targeted warmth directly to the people and objects in their path.

Discrete, stylish heating for undercover outdoor and indoor open areas

Using the radiant heating principle, HEATSTRIP® can provide effective and energy efficient comfort heating for undercover outdoor and indoor open areas. HEATSTRIP® has successfully enabled many entertainment venues such as restaurants, pubs and clubs to utilise their outdoor dining areas day and night, through all seasons. Within your workplace or business, HEATSTRIP® can provide comfort heating for designated outdoor smoking and leisure areas, as well as for workstation spot heating in factories, warehouses and showrooms. Within your home, HEATSTRIP® can provide comfort heating for undercover alfresco dining and BBQ area, patios, verandas, courtyards and balconies.

Subtle, minimalist design

The stylish, slimline black face of the HEATSTRIP® does not emit light or glow when in use, blending elegantly into your décor. Ceiling, wall and umbrella mounting options ensure that your valuable floor and table space is not wasted.

Efficient, cost effective electric heating

The innovative design of the HEATSTRIP® enables comfortable and even heat dispersion from the heater surface with minimal operating costs.

Design flexibility

Four HEATSTRIP® models are available, ensuring the heating requirements of any undercover outdoor or open indoor area is possible. Brackets for direct ceiling or wall/ceiling angled mounting are supplied as standard.

Optional HEATSTRIP® accessories include beam or fixed umbrella mount brackets, extension mount brackets, chain suspension brackets, twin mount brackets and flush mounting enclosures.



Minimal maintenance

The HEATSTRIP® incorporates no internal moving parts ensuring quiet and virtually maintenance free operation.

Australian Product

Designed, engineered and assembled in Australia the HEATSTRIP® Classic is fully backed by a 24 month residential warranty, and 12 month commercial warranty.

Stylish design— *The Heater that is a Design Feature!*

The attractive HEATSTRIP® comes with a standard black face and anodised alloy rear casing.

Easy to use

The standard HEATSTRIP® Classic is controlled by a simple on/off operation, either when plugged directly into a power point, or hard-wired via a wall mounted on/off switch. The unit takes approximately 15 minutes to heat up to maximum temperature and approximately 30 minutes to cool down, depending upon the ambient temperature. Please don't forget to turn it off.

We recommend installing your HEATSTRIP® with a timer controller to ensure the unit is turned off after a pre-set time. Thermofilm recommends Model TT-MTM2 controller, which includes a timer function and temperature control functions.



Specifications - Australia

MODEL	POWER (WATTS)	CURRENT (AMPS)	DIMENSIONS (mm)	WEIGHT (Kg)	LEAD LENGTH (mm)	PLUG
THH1500A	1500	6.3	924 x 165 x 48	5	1000	YES
THH1800A	1800	7.5	1104 x 165 x 48	6	1000	YES
THH2400A	2400	10	1364 x 165 x 48	7	1000	YES
THH3200A	3200	13.3	1774 x 165 x 48	9	500	NO

MODEL

HEATER TYPE	High intensity electric radiant overhead heater with high surface area profiled alloy	
OUTPUT	Refer to model code chart above	
POWER	230-240 Volts Nominal at 50—60 Hertz, Single Phase	
CONNECTION	3 Core Cable 2.5mm ²	
APPROVALS	AUSTRALIA/NZ	
MOUNTING HEIGHT	MINIMUM RECOMMENDED MAXIMUM	2.1 m 2.3 m to 2.5 m 2.7 m in a fully enclosed outdoor area (For higher ceiling heights, units can be lowered using optional bracket kits or refer to the Heatstrip Max range)
MOUNTING OPTIONS	Suitable for ceiling, wall, beam, fixed umbrella and recess mounting. Also available for extension mount using rigid fixing poles and chain mount bracket.	
PROTECTION RATING	IP55 Protection from water ingress from all directions	
COUNTRY OF MANUFACTURE	Australia	

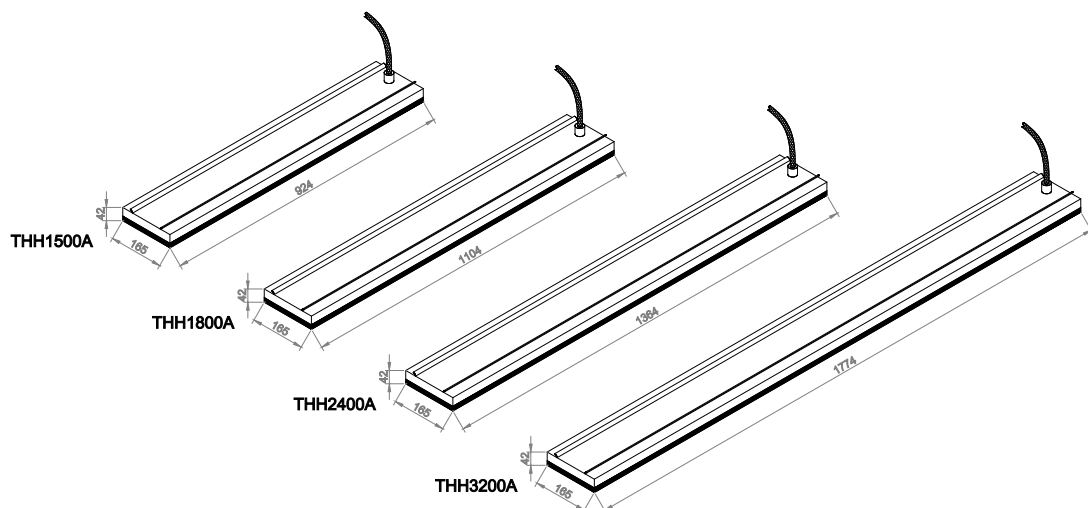



Specifications - International

HEATSTRIP® is supplied to many international markets, and therefore is available in a range of voltages and lead configurations to meet local market approvals. HEATSTRIP® is fully compliant to the following international standards.

Europe CE, ROHS, IEC 60335-2-30:2002
 USA/Canada UL/CSA E321442
 Japan PSE

MODEL	REGION	VOLTAGE (Volts)	POWER (WATTS)	CURRENT (AMPS)	DIMENSIONS (mm)	WEIGHT (Kg)	LEAD LENGTH (mm)	PLUG
THH1500AEU	EUROPE	230	1500	6.3	924 x 165 x 48	5	1000	YES 230V
THH2400AEU	EUROPE	230	2400	10	1364 x 165 x 48	7	1000	YES 230V
THH3200AEU	EUROPE	230	3200	13.3	1774 x 165 x 48	8	500	NO
THH1500AUK	UNITED KINGDOM	240	1500	6.3	924 x 165 x 48	5	1000	YES 240V
THH2400AUK	UNITED KINGDOM	240	2400	10	1364 x 165 x 48	7	1000	YES 240V
THH3200AUK	UNITED KINGDOM	240	3200	13.3	1774 x 165 x 48	8	500	NO
THH1500AUL	NORTH AMERICA	115	1500	6.3	924 x 165 x 115	5	NONE	NO
THH2400AUL	NORTH AMERICA	240	2400	10	924 x 165 x 115	7	NONE	NO
THH3200AUL	NORTH AMERICA	240	3200	13.3	924 x 165 x 115	9	NONE	NO
THH2400AUM	NORTH AMERICA	208	2400	10	924 x 165 x 115	7	NONE	NO
THH3200AUM	NORTH AMERICA	208	3200	13.3	924 x 165 x 115	9	NONE	NO
THH1300AJP	JAPAN	100	1300	6.3	924 x 165 x 48	5	1000	YES 100V
THH1400AJP	JAPAN	200	1400	7.5	924 x 165 x 48	5	1000	YES 200V
THH1600AJP	JAPAN	200	1600	10	1104x 165 x 48	6	1000	YES 200V



Operating cost comparison

In many instances, patio heaters powered by gas bottles are used as an outdoor heating source. The below table shows the operational cost comparison between HEATSTRIP® and a bottled gas outdoor heater. Not only are the hourly running costs considerably less with HEATSTRIP®, but you never have to worry about running out of gas, no refilling, no unattractive gas bottle to waste space; and HEATSTRIP® actually improves the value of your property.

RUNNING COST	OUTDOOR GAS HEATER	HEATSTRIP® CLASSIC ELECTRIC RADIANT HEATER			
		THH1500A	THH1800A	THH2400A	THH3200A
PER HOUR	\$2.78/hr	\$0.30/hr	\$0.36/hr	\$0.48/hr	\$0.64/hr
PER YEAR	\$500.40	\$54.00	\$64.80	\$86.40	\$115.20

Notes:

- Calculations of hourly running cost for outdoor gas heater is based on \$25.00 average to fill a 9kg gas bottle and average running time of 9 hours. $\$25.00 / 9 \text{ hours} = \2.78 per hour
- Electricity rate of 20.0 cents/kWh
- All calculations are excluding GST.
 - 1.5kW x 0.20 cents = \$0.30 or 30 cents per hour
 - 1.8kW x 0.20 cents = \$0.36 or 36 cents per hour
 - 2.4kW x 0.20 cents = \$0.48 or 48 cents per hour
 - 3.2kW x 0.20 cents = \$0.64 or 64 cents per hour

Calculations of yearly running cost are based on 180 hours usage

- 180 hours x \$2.78 = \$500.40 yearly running cost for outdoor gas heater
- 180 hours x \$0.30 = \$54.00 yearly running cost for 1500W HEATSTRIP®
- 180 hours x \$0.36 = \$64.80 yearly running cost for 1800W HEATSTRIP®
- 180 hours x \$0.48 = \$86.40 yearly running cost for 2400W HEATSTRIP®
- 180 hours x \$0.64 cents = \$115.20 yearly running cost for 3200W HEATSTRIP®





Spot heating principle

In most outdoor or difficult-to-heat indoor applications, there are 2 options when looking at the size and quantity of the heaters required.

Option 1 is to comfort heat the entire area based on the total dimensions of the space, regardless of whether the entire area is being fully occupied.

Option 2 is to spot heat the high use areas, such as over outdoor tables, BBQ's, lounges, assembly lines or indoor workstations.

Often it is more practical and efficient to spot heat high use areas. Spot heating will reduce both the initial capital cost as well as the ongoing running costs. Spot heating will allow the area to be "zoned", meaning only the areas that are being used are heated, such as tables in a restaurant or outdoor alfresco area.

Option 1 and 2 show a comparison between heating an entire area or spot heating over a table.

The bottom layout shows the flexibility of using HEATSTRIP[®] to provide a comfortable environment, even when the layout of the area is very unusual.

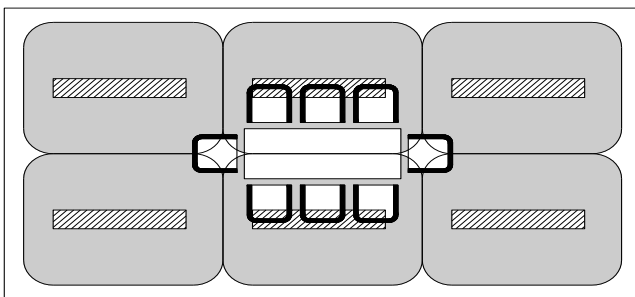

Option 1: 6 x THH2400A

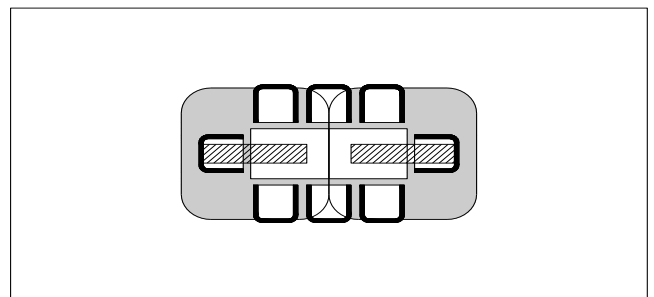

Option 2: 2 x THH2400A

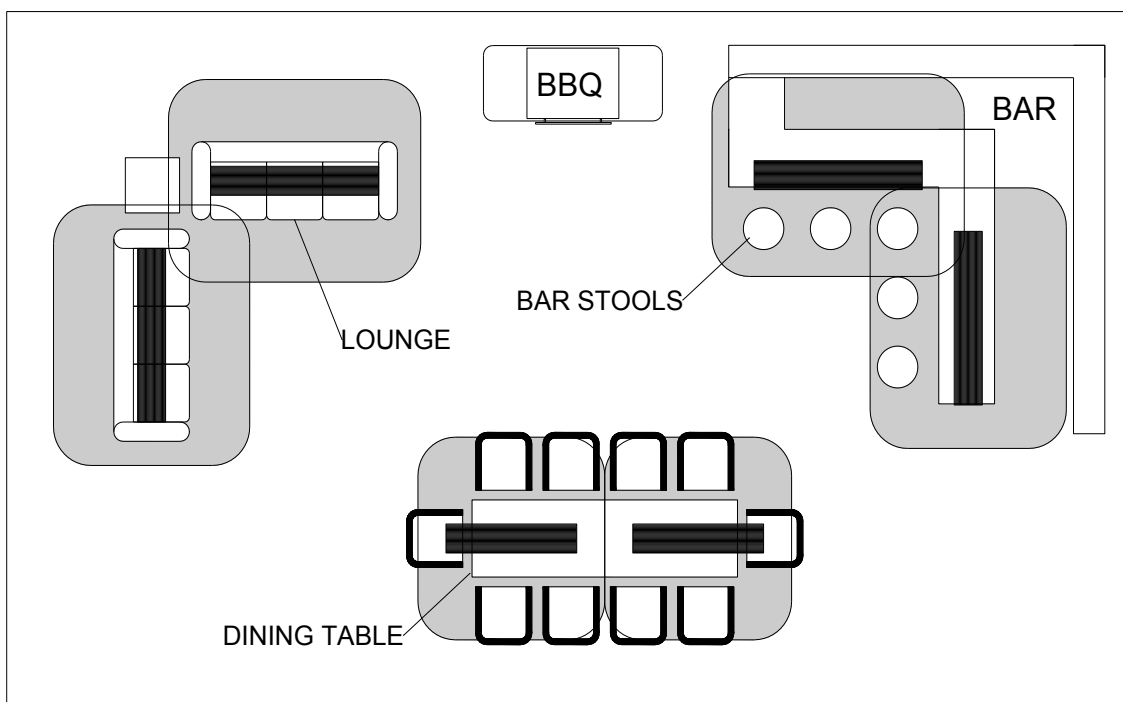



Radiant footprint

HEATSTRIP® electric heaters produce radiant heat which heats objects rather than the air. Therefore, it is imperative that objects to be heated (ie. people), are within the direct radiant footprint of the heater.

The diagram to the left shows the radiant footprint of HEATSTRIP® Classic, and is an approximate guide based on a fully enclosed outdoor environment.

This diagram shows that the maximum heat output is found directly under the heater, and the temperature decreases as you move away from the heater.

It highlights the importance of maintaining recommended mounting heights, and if possible, positioning the heater directly above the area to be heated.

Note that the temperature is the same for all 4 models, regardless of the wattage. However, as the size increases and the length of the unit increases, the radiant footprint will be longer.

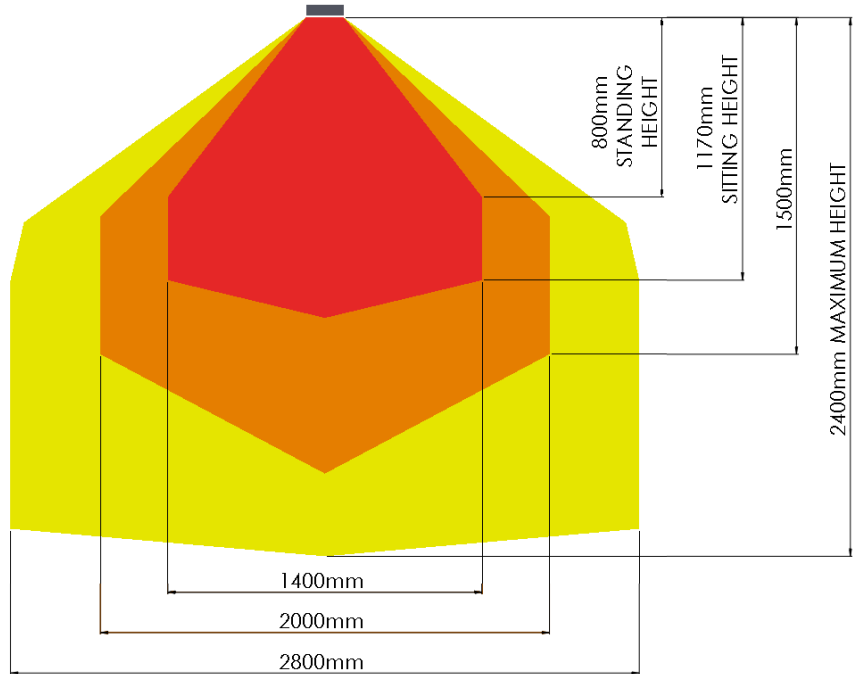

The below diagrams show the approximate heating area for each model, based on both an indoor and outdoor enclosed environment, with direct overhead mounting.

The radiant footprint is reduced in angled, wall mounted installations.

HEATED AREA

INDOOR SPOT HEATING

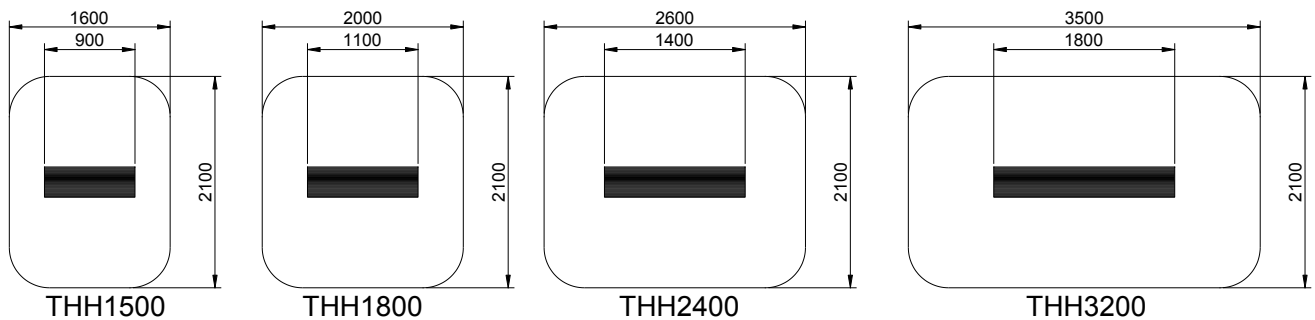

HEATED AREA

OUTDOOR ENCLOSED AREA

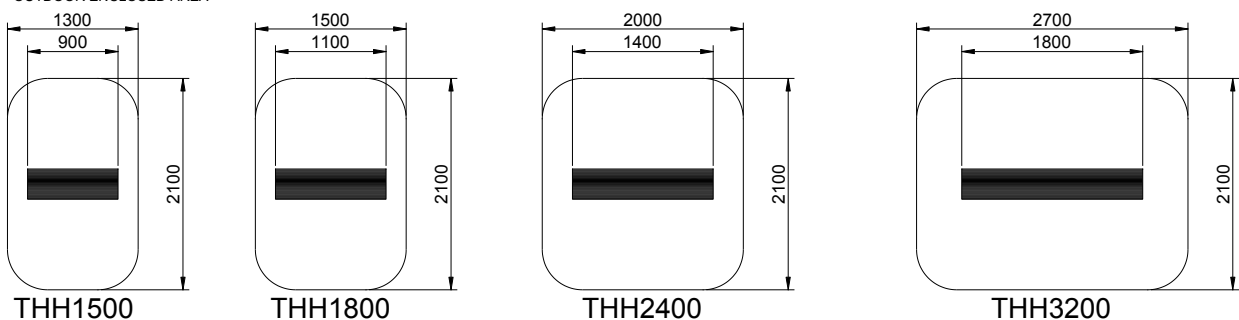



Selection guide

General recommendations for **HEATSTRIP® Classic**:

- Ideal mounting height: 2.3m to 2.5m. Maximum is 2.7m in a fully protected/enclosed outdoor environment.
- Ideal mounting location: ceiling mounted, directly above area to be heated (eg. above a table)
- Based on the radiant footprint of the previous page, for a protected outdoor area, a minimum of 500W/m² is required. For indoor spot heating, a minimum heating capacity of 400W/m² is recommended.

The table below outlines the coverage of each **HEATSTRIP® Classic** model based on 3 different scenarios with direct overhead mounting. For example, for an outdoor area that is protected from prevailing winds by walls, café blinds etc, Model THH 1500A will cover 3m² and Model THH2400A will cover 4.8m².

For angled wall mounting applications, the coverage is reduced by up to 40%.

MODEL	INDOOR PROTECTED (m ²)	OUTDOOR ENCLOSED (m ²)	OUTDOOR EXPOSED (m ²)
THH 1500A	3.75	3	2.5
THH 1800A	4.5	3.6	3
THH 2400A	6	4.8	4
THH 3200A	8	6.4	5.3

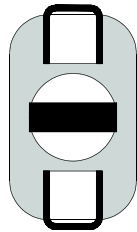



Table layout

For the majority of outdoor applications, the most effective method is to spot heat a table or similar area. The diagrams below provide an easy selection guide for the approximate model and quantity of heaters required to heat common residential table settings.

Selections are based on HEATSTRIP® Classic being mounted at 2.4m from the floor in a fully enclosed undercover outdoor area.



THH1500

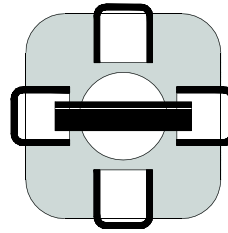

THH2400

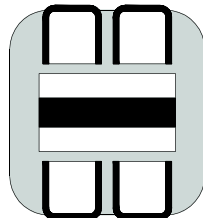

THH2400

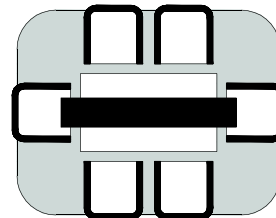

THH3200

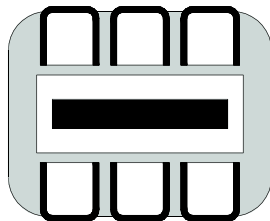

THH3200

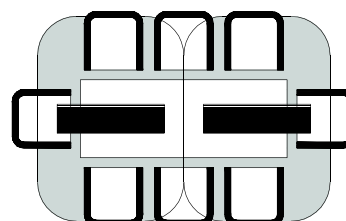

2 x THH1800

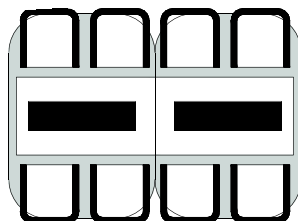

2 x THH1800

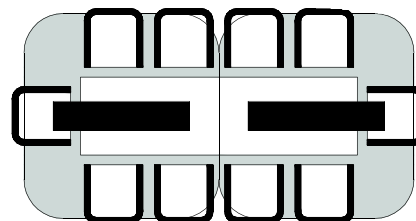

2 x THH2400

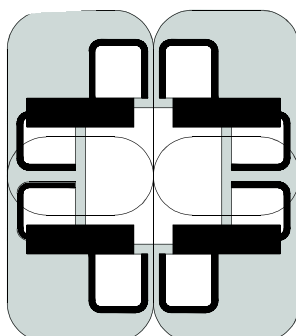

4 x THH1800

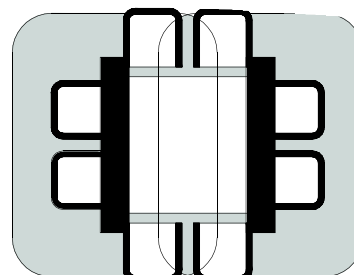

2 x THH3200



Installation Requirements

The ideal mounting position for the HEATSTRIP® Classic is on the ceiling directly above the area to be heated. If this is not possible, HEATSTRIP® can be mounted on a wall and angled downwards. In this situation, ensure the mounting height is in the range of 2.1m to 2.7m and the table is within 2.5m of the wall.

For mounting heights more than 2.7m, we recommend the use of the optional accessories to reduce the height of the heater to 2.3m—2.5 m. This will increase the effectiveness of your HEATSTRIP®. Refer to the Mounting Accessory section for more information.

Electrical connections/GPO's should not be located at the back of the heater. They should be located outside the physical footprint of the units to minimize heat build-up behind the units.

If the heater is to be mounted on an incline (e.g. vaulted ceiling), ensure the electrical connection is located at the lowest point of the heater.

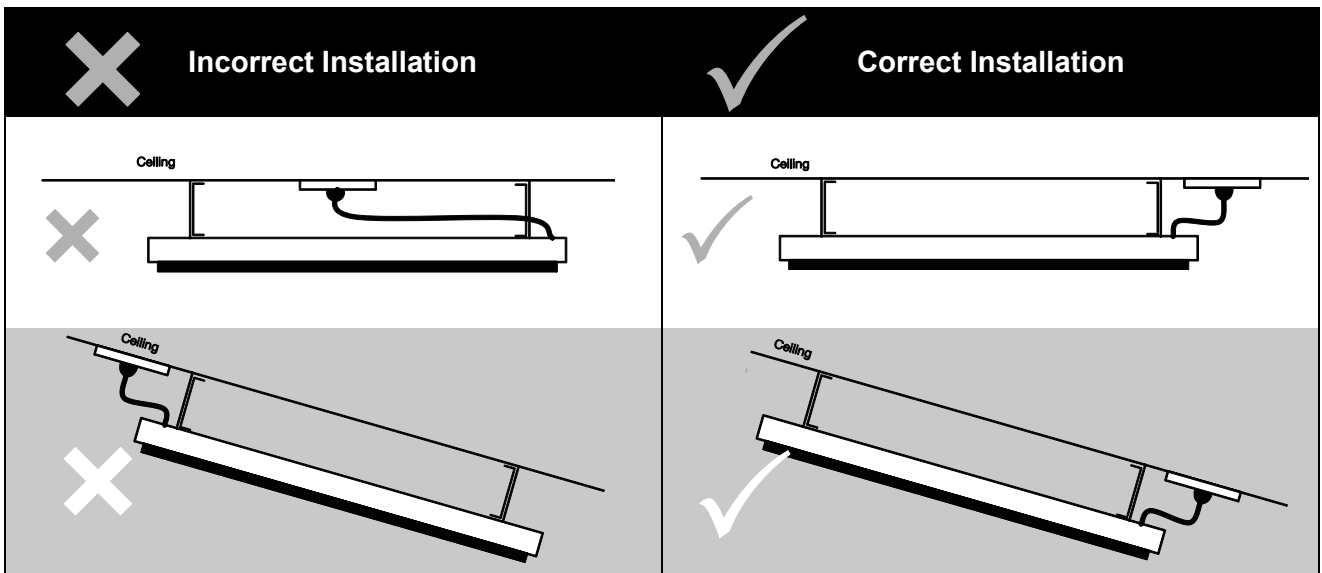

CEILING

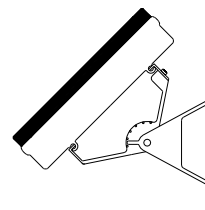

The heating surface must never be directed toward the ceiling



Installation location —the below diagrams provide the minimum recommended clearances.

LIGHT, FAN OR SPRINKLER MUST NOT BE BELOW THE HEATER

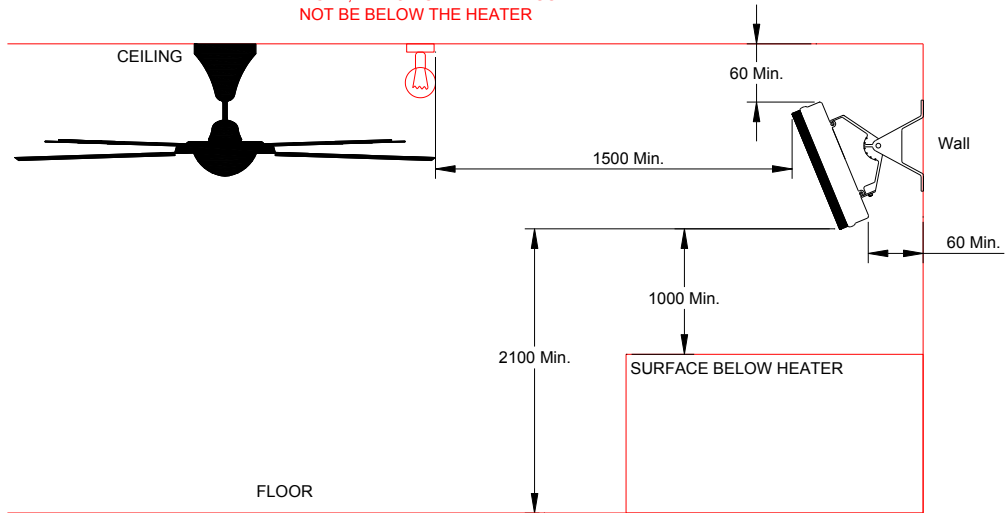

Angled Wall Installation

LIGHT, FAN OR SPRINKLER MUST NOT BE BELOW THE HEATER

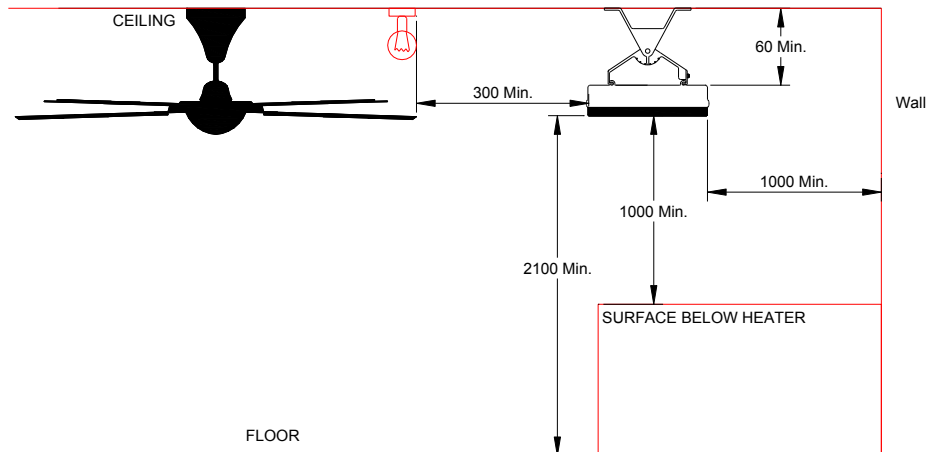

Ceiling Installation

LIGHT, FAN OR SPRINKLER MUST NOT BE BELOW THE HEATER

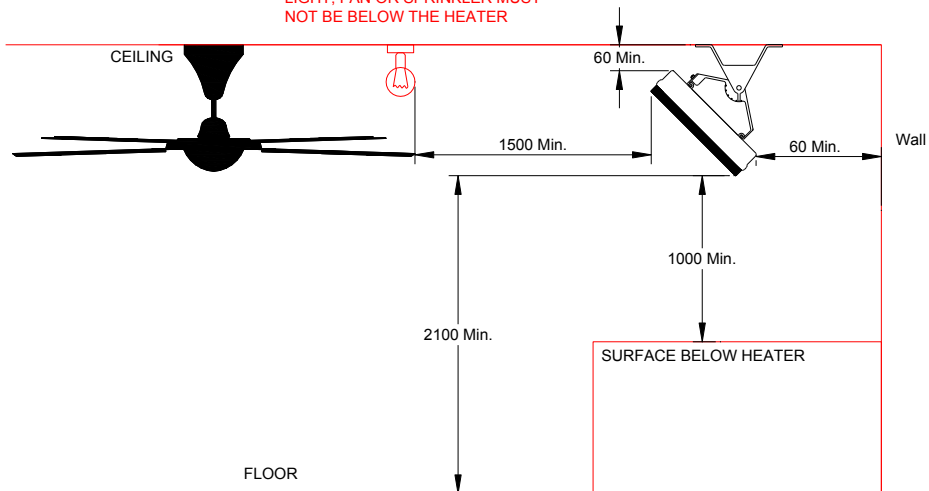

Angled Ceiling Installation



Mounting options

Installing the HEATSTRIP® Classic is simple and easy using the standard mounting brackets supplied. For other irregular locations there are range of mounting options available - refer to diagrams below

The HEATSTRIP® Classic can be mounted directly to the ceiling, angled downwards on a wall, fitted flush with the ceiling, suspended on chains or poles, attached to beams or poles, mounted end-to-end, or 2 units side-by-side together. Refer to the following pages for more detailed information on each mounting option.

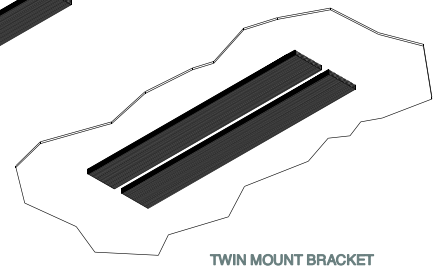
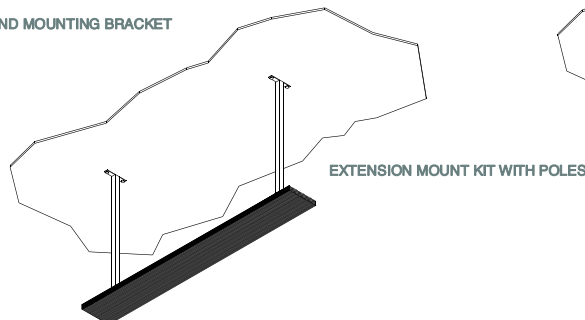
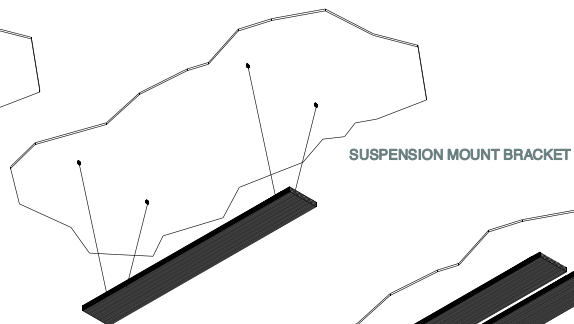
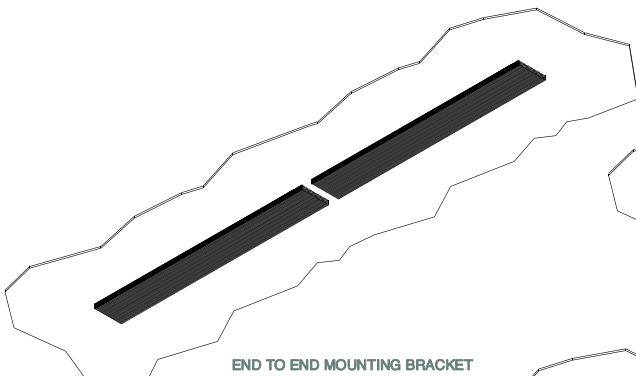
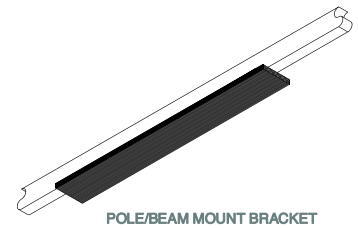
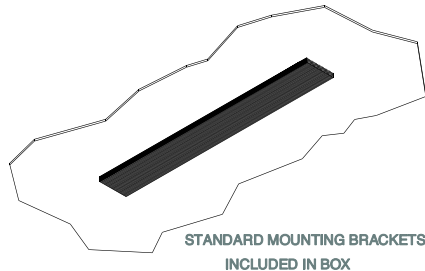
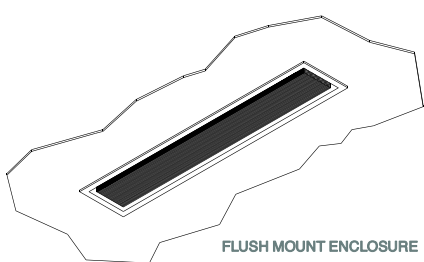
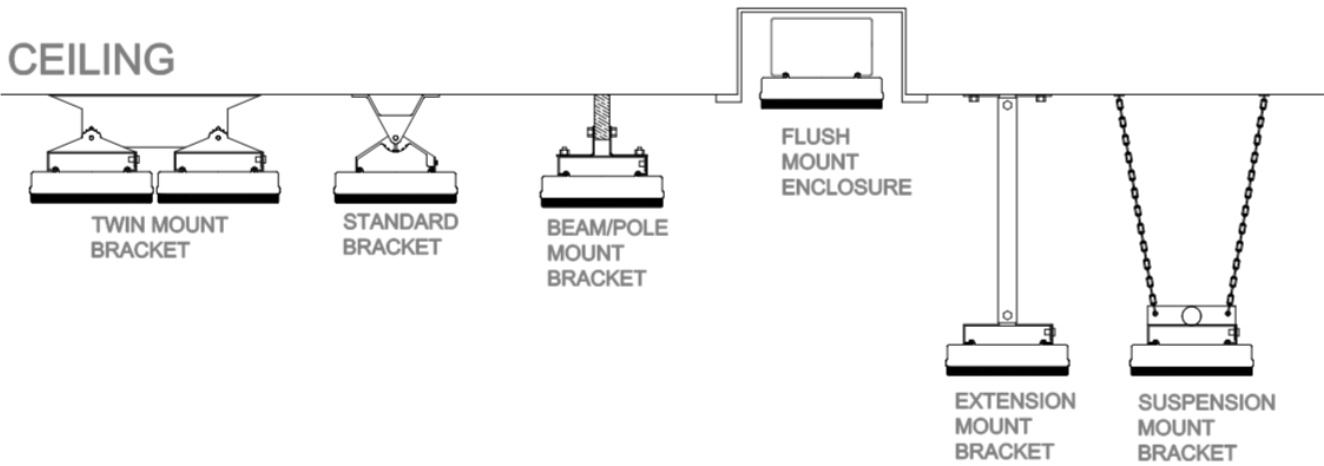



Standard mounting brackets

The HEATSTRIP® Classic comes with a pair of standard mounting brackets. These adjustable brackets allow direct ceiling or wall mount, and come with preset angle options of parallel, 22.5° and 45°.

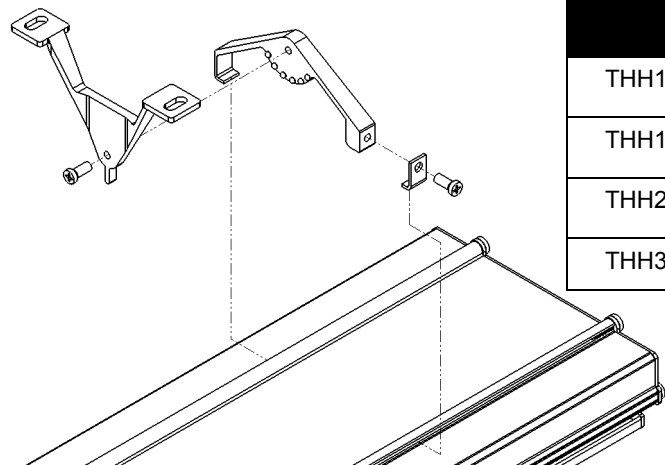
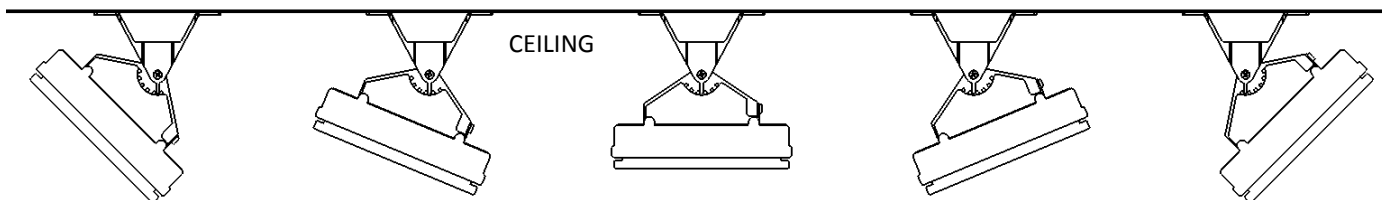

MODEL	"X" MINIMUM DISTANCE (mm)
THH1500A	550
THH1800A	710
THH2400A	1000
THH3200A	1470

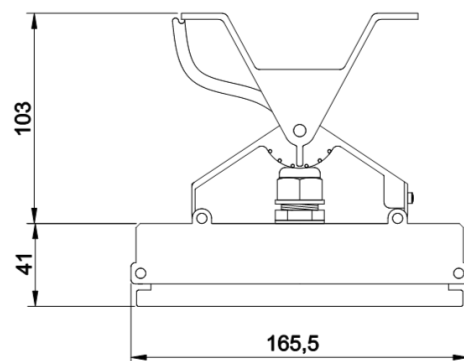
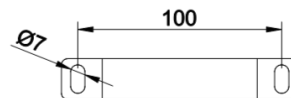
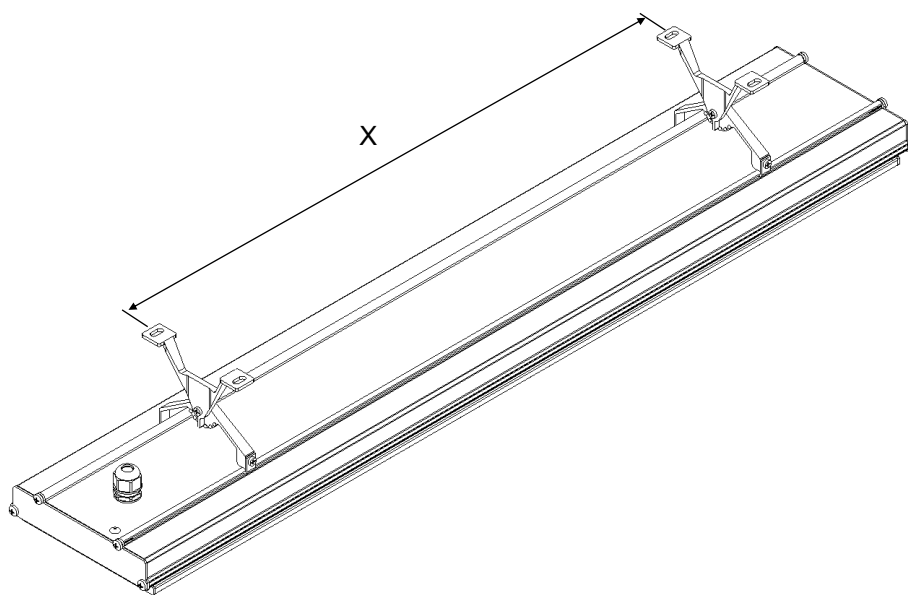
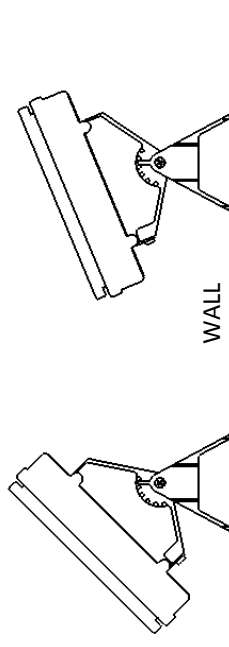

PART No	PACKAGED DIMENSIONS (mm)	WEIGHT (kg)	MATERIALS
ZBRAK-103	125 x 150 x 40	0.2	ALLOY



Flush mount enclosure

The Flush Mount Enclosure is an ideal way to neatly install the HEATSTRIP® into a ceiling. They are available for all HEATSTRIP® Classic models, and are supplied as a one-piece unit suitable for mounting individual heaters. Flush mounting can be used with plaster or timber lined ceiling materials.

An ideal mounting height is 2.3m-2.5m, with a maximum ceiling height of 2.7m in an outdoor enclosed environment. Maximum mounting heights should be strictly followed, otherwise the performance of the units may be reduced.

The fascia of the enclosure is manufactured from 316 Stainless Steel and the rear casing is black zinc coated steel.

Please refer to the Flush Mount Enclosure Installation Manual for more detailed installation information.

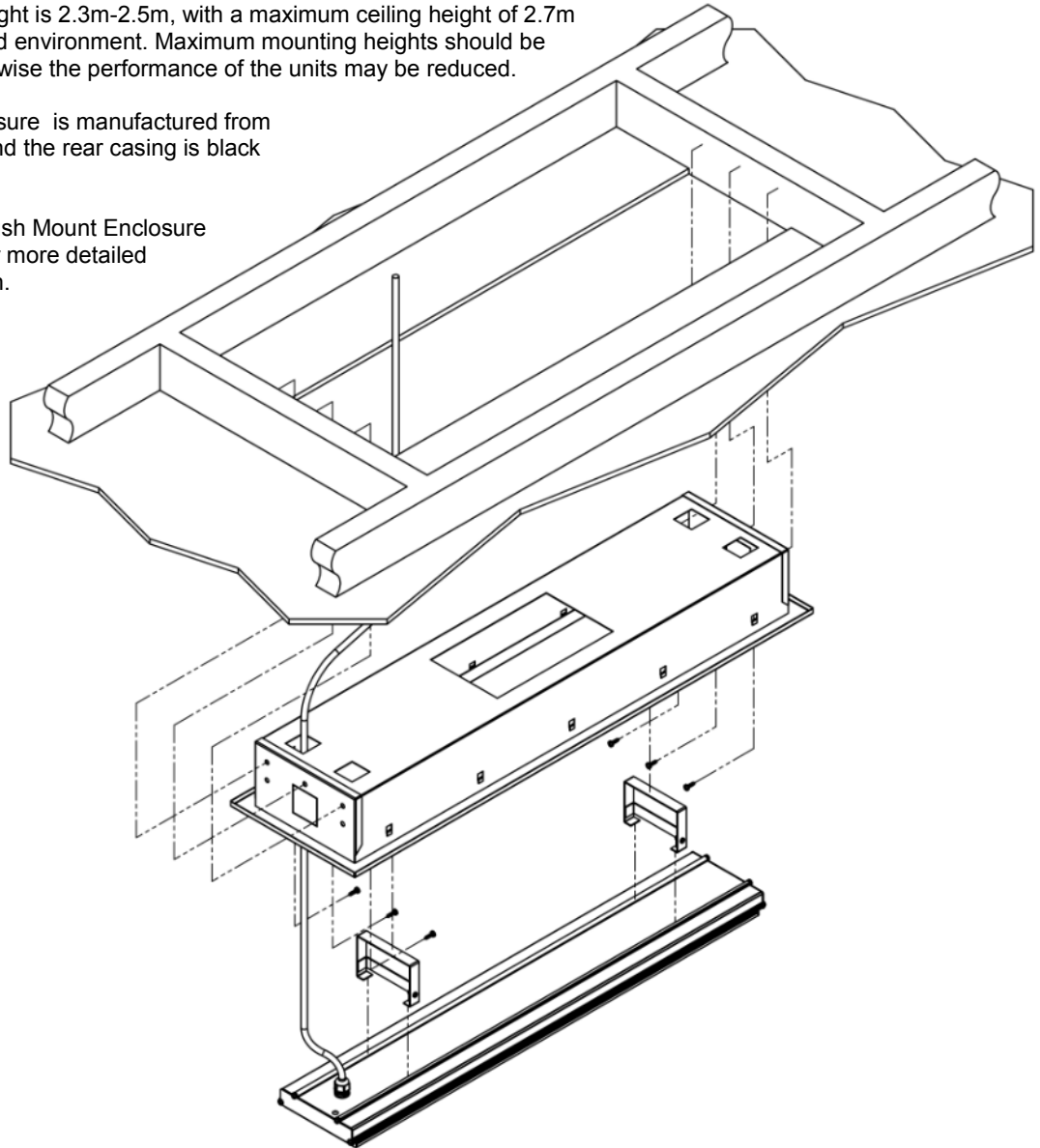

SUITABLE FOR MODELS	PART No	HOLE CUTOUT DIMENSIONS (mm)	OVERALL DIMENSIONS (mm)	WEIGHT (kg)
THH 1500A	THHAC-009	980 x 230	1030 x 280 x 125	5.5
THH 1800A	THHAC-010	1160 x 230	1210 x 280 x 125	6
THH 2400A	THHAC-011	1420 x 230	1470 x 280 x 125	8
THH 3200A	THHAC-012	1830 x 230	1880 x 280 x 125	9



Pole / beam mounting kit

PART No	PACKAGED DIMENSIONS (mm)	WEIGHT (kg)	MATERIALS
THHAC-001	150 x 150 x 50	0.5	316 SS

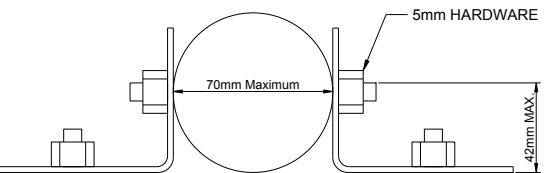
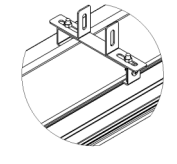
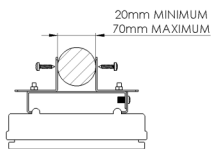
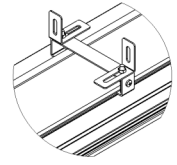
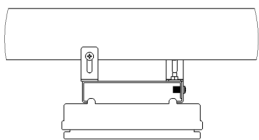
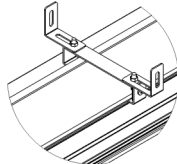
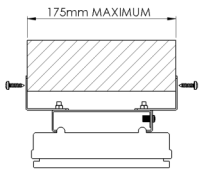
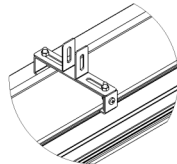
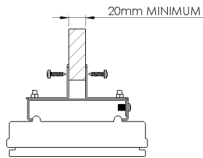
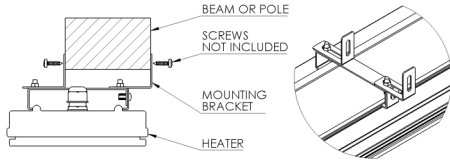

The optional Pole/Beam mounting bracket kit can be used to mount HEATSTRIP® Classic onto wooden beams, rafters, poles, umbrellas struts etc.

Screws for connection to the beam or pole are not included.

Minimum pole diameter 20mm.

Maximum pole diameter 70mm.

This mounting option is suitable for umbrella struts.

The beam/pole can be placed directly on top of the mounting bracket. No clearance is required from the top bracket to the bottom of beam/pole.

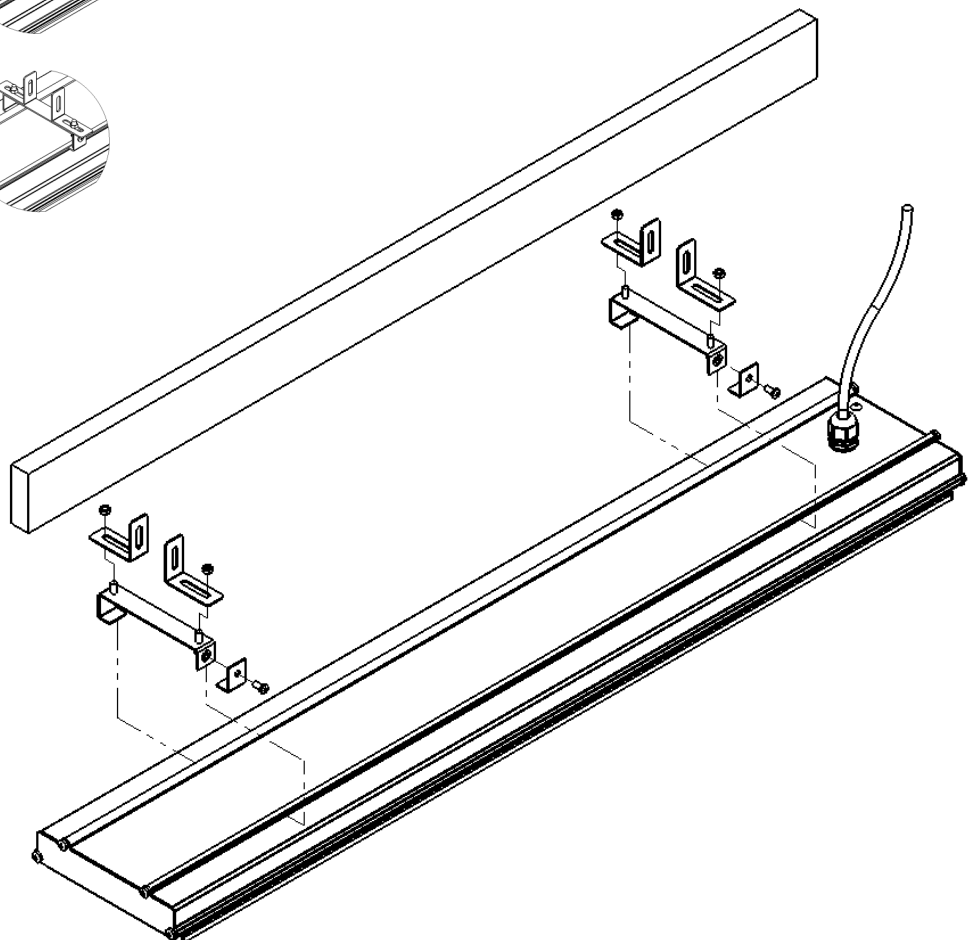



Twin mounting bracket

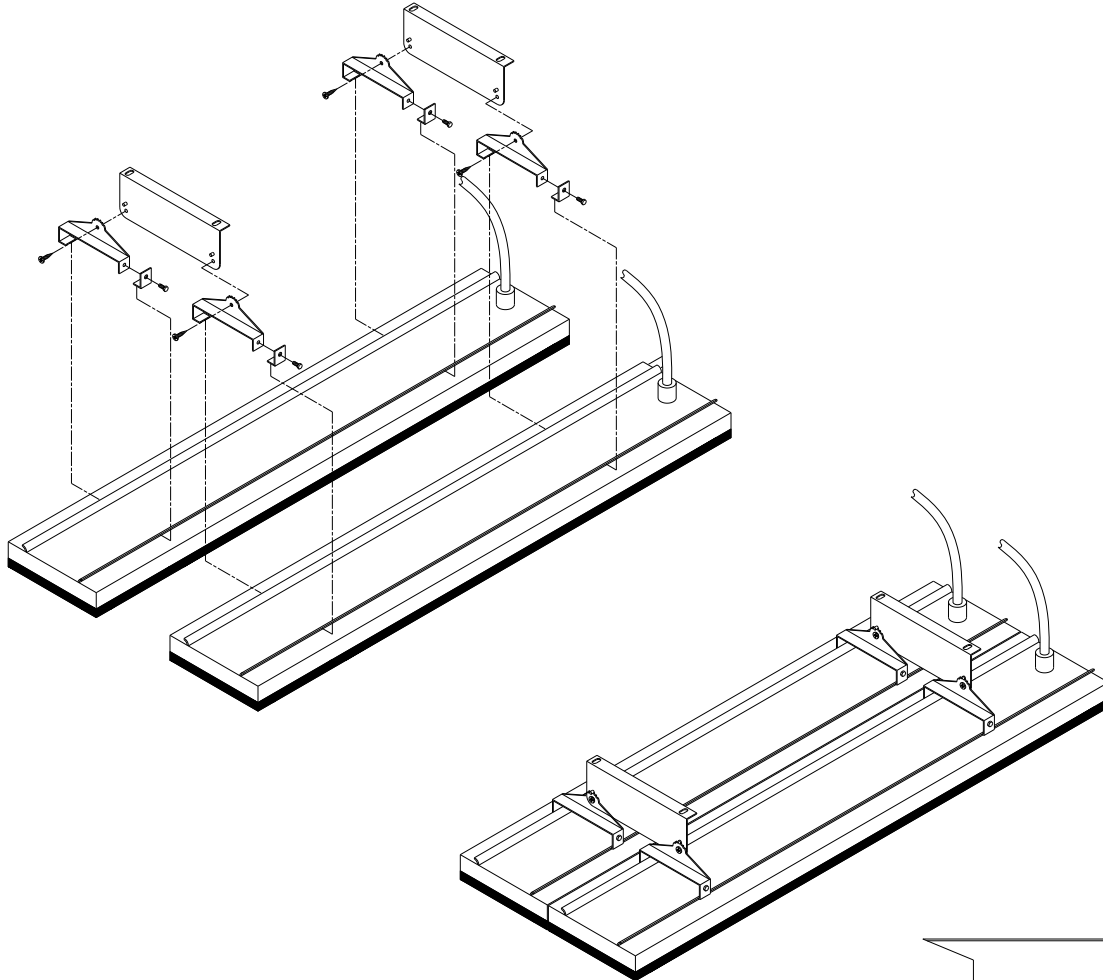

The optional Twin Mount bracket allows for two (2) units of HEATSTRIP Classic to be mounted side-by-side, either in parallel or angled as per the diagram on the right. This is ideal for applications when a wider heat coverage is required, or when there are mounting restrictions or limitations.

The Twin Mount bracket can also be used with the Extension Mount bracket and Pole Kit, to lower the units from a high ceiling.

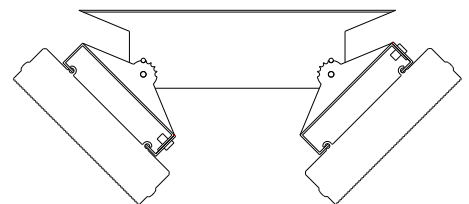
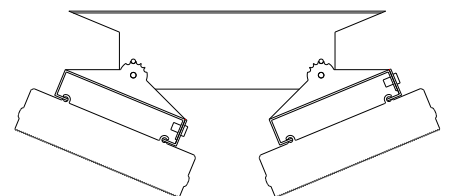
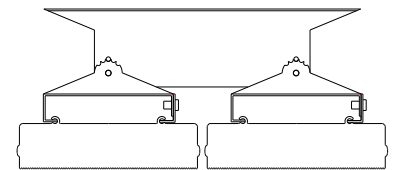

PART No	PACKAGED DIMENSIONS (mm)	WEIGHT (kg)	MATERIALS
THHAC-016	300 x 50 x 50	0.25	316 SS



End to end mounting bracket

The end to end bracket allows multiple units to be joined in a straight line for maximum heat performance and aesthetic appeal. This is ideal for applications such as long rows of tables and assembly lines, where a constant heat coverage is required.

The bracket allows for a 50mm gap between units and an opening for the power connection. As per the diagram below, units should be mounted with the power leads together.

The end to end bracket can be used with either the standard ceiling/wall mount bracket or the extension bracket & pole kit.

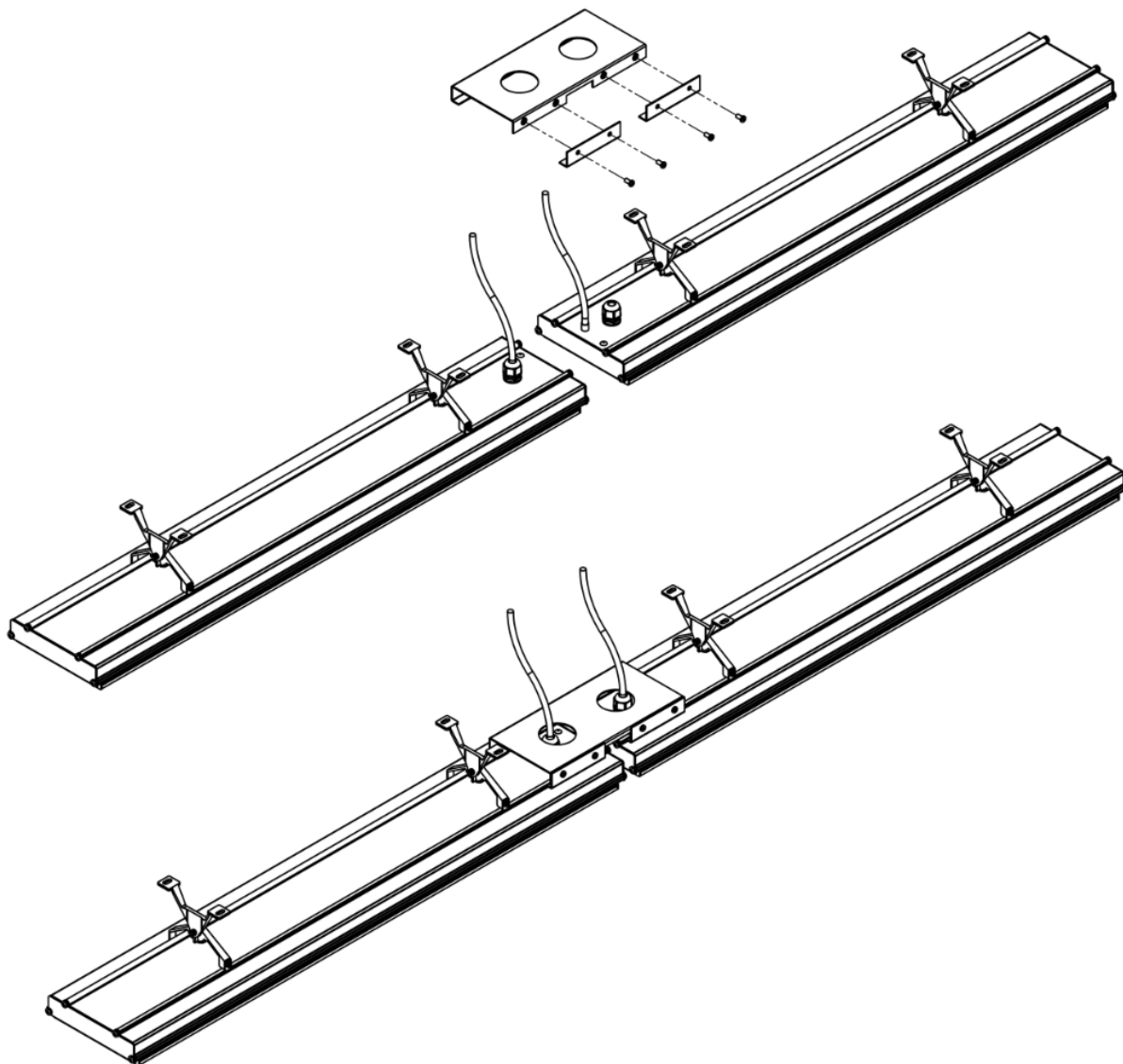

PART No	PACKAGAED DIMENSIONS (mm)	WEIGHT (kg)	MATERIALS
THHAC-017	300 x 150 x 50	0.5	316 SS



Suspension mount bracket

If the space to be heated is an enclosed outdoor environment with a ceiling height of 2.7m or more, it is recommended to lower the heaters to an ideal mounting height of 2.3m—2.5m. The Suspension Mount bracket provides a cheap, easy and effective option for lowering the HEATSTRIP® Classic from high ceilings.

The bracket is designed to be used with chains or wires.

There can be multiple chain/wire arrangement options, as per the diagram below.

Note: chains or cable are not supplied with heaters or brackets.

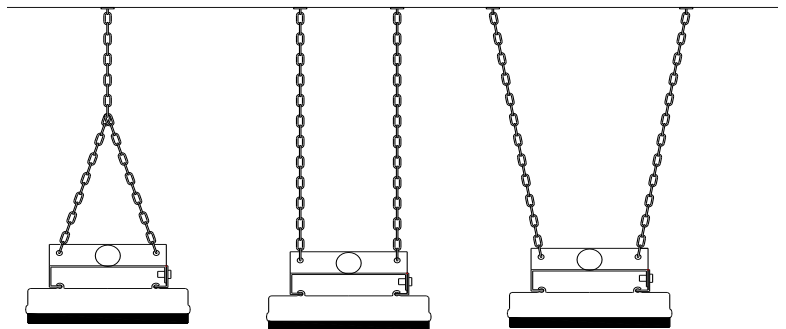
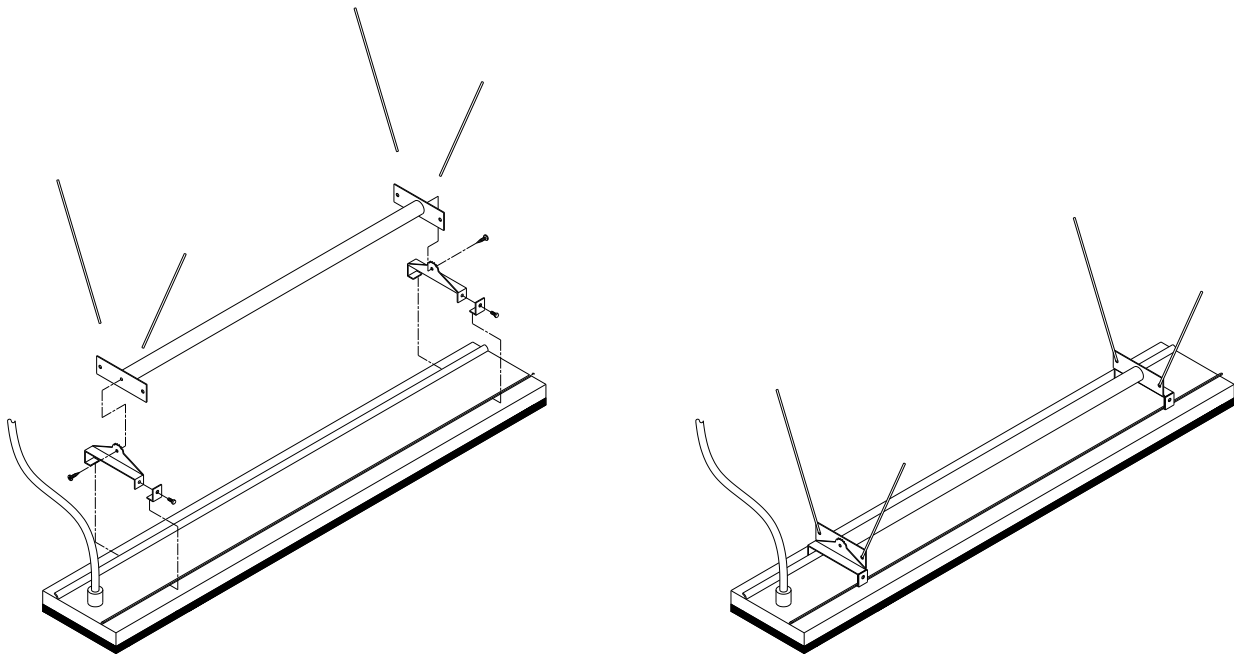

SUITABLE FOR MODELS	PART No	PACKAGED DIMENSIONS (mm)	WEIGHT (kg)	MATERIALS
THH1 500A THH 1800A	THHAC-002	300 x 150 x 50	1	316 SS
THH 2400A THH 3200A	THHAC-003	1200 x 120 x 50	2	316 SS



Extension Mount Bracket

The Extension Mount bracket allows HEATSTRIP® Classic units to be lowered from high ceilings using rigid connections. The brackets are designed to be used with 25mm x 25mm x 1mm tube (SHS), and can be supplied as brackets only for customising the length of the drop on site, or supplied as a complete kit with brackets, pre-cut poles and connections. The standard length options as part of the kit are 150mm, 300mm, 600mm, 900mm and 1200mm.

The kits include all brackets, poles and screws necessary for connection to the heaters, however it does not include screws for attachment to the ceiling.

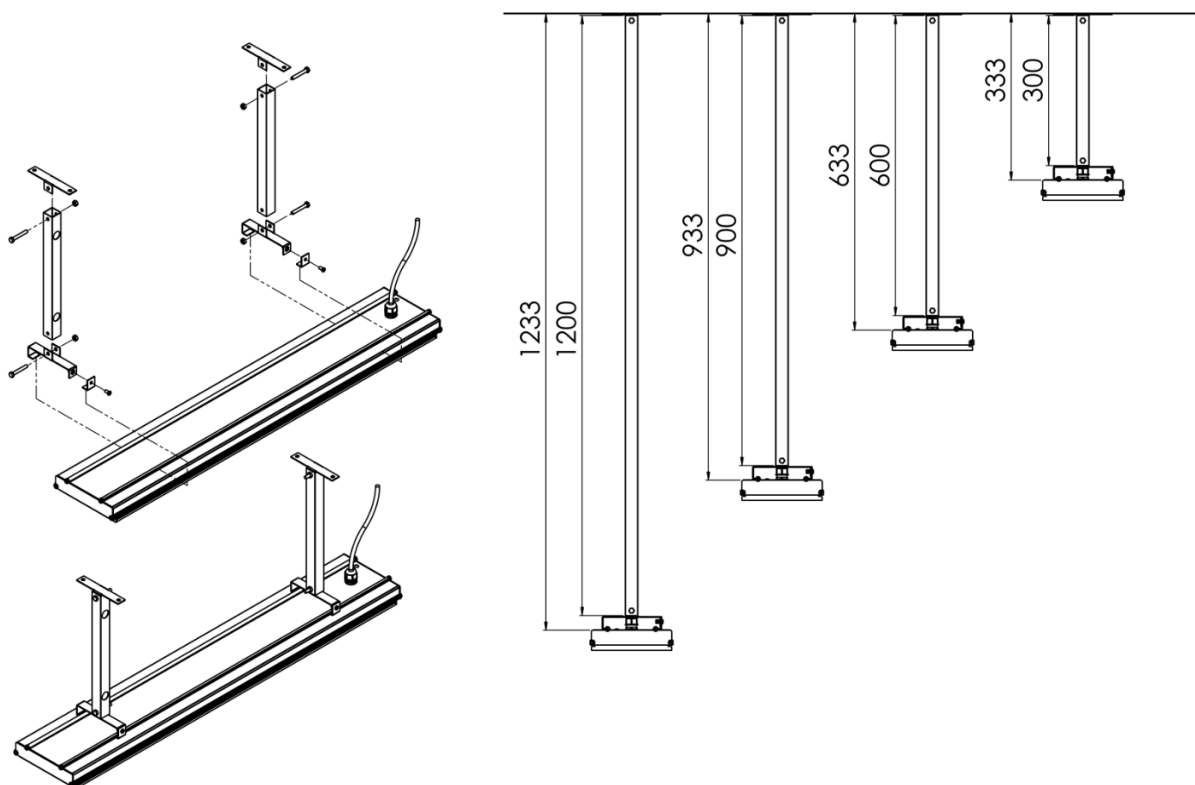

PART No	PACKAGED DIMENSIONS (mm)	WEIGHT (kg)	MATERIALS	NOTES
THHAC-004	150 x 150 x 50	1	316 SS	Brackets only (for use with 25x25x1mm tube)
THHAC-005	300 x 150 x 50	2	316 SS	Kit includes 2x300mm extension pole, screws and brackets
THHAC-006	600 x 150 x 50	2	316 SS	Kit includes 2x600mm extension pole, screws and brackets
THHAC-007	900 x 150 x 50	2.5	316 SS	Kit includes 2x900mm extension pole, screws and brackets
THHAC-008	1200 x 150 x 50	3	316 SS	Kit includes 2x1200mm extension pole, screws



Permanent Umbrella Mounting Guide

HEATSTRIP® Classic heaters can be mounted underneath most commercial grade, permanent umbrella's or shade structures. The material must protect the heater from direct rainfall. All models can be connected to the horizontal umbrellas struts, using the Pole/Beam mounting kit (THHAC-001).

Quick reference guide for spot heating common permanent umbrella structure:

9m2 umbrella area	4 x THH 1500A
12 m2 umbrella area	6 x THH 1500A or 4 x THH 1800A
16 m2 umbrella area	8 x THH 1500A or 6 x THH 1800A

This is a guide only. For more detailed information, please contact the umbrella manufacturer, your nearest HEATSTRIP retailer or Thermofilm.

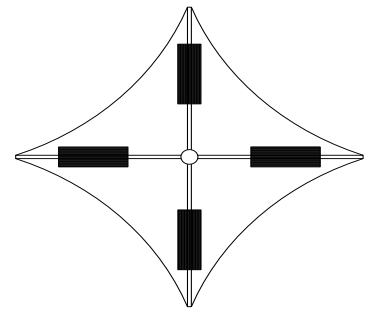
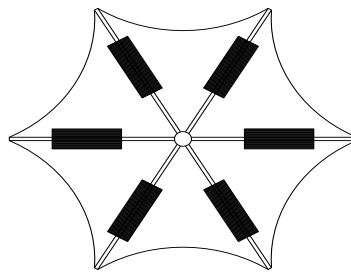
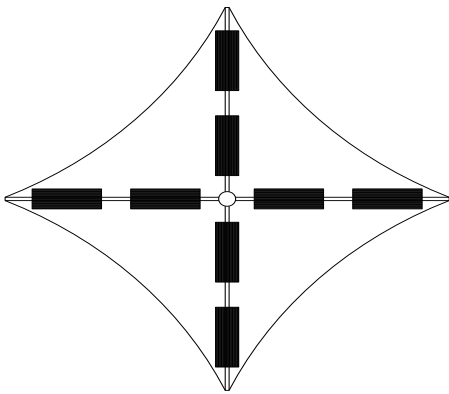



Safety

HEATSTRIP® Classic has an IP rating of 55. This means it is safe for water ingress from all directions. The HEATSTRIP® can be safely hosed down.

HEATSTRIP® has undergone extensive testing both in laboratory conditions, in Thermofilm's manufacturing facility in Melbourne and field trials in Australia and overseas. It is this testing that gives the purchaser the confidence of a high quality product.

Independent laboratory testing has confirmed Thermofilm's full compliance with Australian and other International Standards including CE, AS/ANZ, UL/CSA

The heater comes in both plug (1500W, 1800W, 2400W) and hardwired (3200W) versions. In both cases the fixed wiring must be installed by a licensed electrician in accordance with the relevant wiring regulations.

HEATSTRIP® is Class 1 equipment and must be earthed.

In operation, this heater is VERY HOT— do not touch any part of the heater while it is turned on. Do not touch any part until 30 minutes after it is turned off.

This appliance is not intended for use by persons (including children) with reduced physical, sensory or intellectual capabilities, or lack of experience and knowledge, unless they have been given supervision or instruction concerning use of the appliance by a person responsible for their safety. Children should be supervised to ensure they do not play with the appliance.

Do not allow any cables, furnishings, flammable materials or other items come in contact with any surface of the heater.

If installed in wet areas, the heater switches or controls must be located so that they cannot be touched by persons in the bath or shower.

The heater needs to be installed as per the installation instructions paying special attention to the minimum clearances. The heater needs to be mounted on a rigid bracket or fixing.

The heater must not be mounted immediately below or in front of a socket outlet.

In case of a heater fault or damaged supply lead, the appliance should be returned to the point of purchase for return to Thermofilm for repair.

Maintenance

The HEATSTRIP® Classic is made from durable materials, however regular care and maintenance of your heater will help prolong the life of the heater.

It is recommended that you hose down the heater and with a soft cloth gently wipe the surfaces of the heater with a mild detergent to remove the built up contaminants from the environment. Then rinse all detergent off the heater. All chemicals in the atmosphere including cigarette smoke, pollution etc. will tarnish the surface of the heater. In this case, additional cleaning and maintenance may be required. Carrying out the cleaning process at least every three months will reduce the amount of build up and keep the Heatstrip in good condition. If the heater is in a corrosive environment eg. salt spray, we recommend that you clean your heater with a light spray of fresh water every week. After cleaning, turn the heater on for 20 minutes to dry any water residue and prevent water staining.

Before cleaning or inspection activity, the heater must be switched off and cooled down completely.

Do not use any abrasive materials or products to clean the heater, this includes solvents, citrus based cleaners or other harsh cleaning products.

When handling the heater, ensure that your hands are clean or that you use clean gloves as grease or dirt can mark the surface of the heater.

Do not use high pressure water to clean heaters, light water spray only.



HEATSTRIP® Wall Controller with Remote

The HEATSTRIP® Classic can be controlled via a simple on/off wall mounted switch, however it is recommended to use a controller with a variable heat modulator and a timer, to give the best performance and lowest running cost.

TT-MTM2 Wall Controller

This controller is a custom designed and manufactured controller for HEATSTRIP® heaters. It has been designed for ease of use and to provide low running costs of your heater. It provides both temperature control (allowing the user to turn the heat output up or down depending on the ambient temperature and conditions) and a timer for automatic heater shut-off operation.

The timer function has four settings: 1 hour, 2 hours, 4 hours or constantly on. This feature is ideal for applications such as BBQ, alfresco areas, restaurant dining, assembly line production etc. when continuous heat is not required. The timer also reduces the likelihood of heaters being inadvertently left turned on.

Depending on the ambient temperature there may be a requirement to adjust the heat output of the heater. The controller has 3 settings, they are High, Medium and Low.

The controller allows a combination of the multiple timer (1/2/4 hour) and heat outputs (High/Medium/Low).

The controller comes with a remote control unit which provides convenient control of the heater power output and timer functions.

Controlling multiple heaters

It is possible to use one wall controller to control multiple heaters. The wall controller is rated at 16 Amps and 240 volts. For a larger current draw, talk to your electrician who can use a relay to connect more units.

Remote pairing

All units operate using the same remote control frequency, therefore, multiple wall controllers can be operated using a single remote control.

The remote will function at distances of over 8m when used in a straight line. This distance reduces when used at an angle.

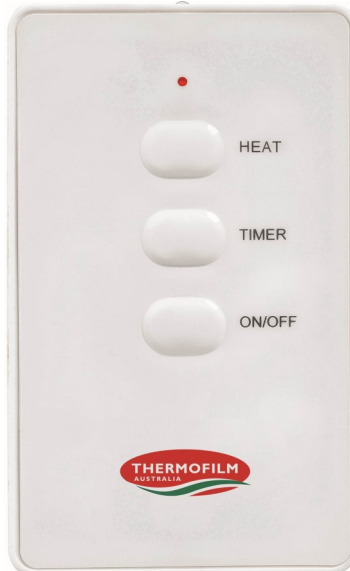

MODEL	MAXIMUM VOLTAGE (Volts)	MAXIMUM CURRENT (Amps)	PACKAGED DIMENSIONS (mm)	UNIT WEIGHT (kg)
TT-MTM2	240	16	150 x 95 x 55	0.3



TT-MTM2 CONTROLLER INSTALLATION GUIDE

Controller Wiring Example

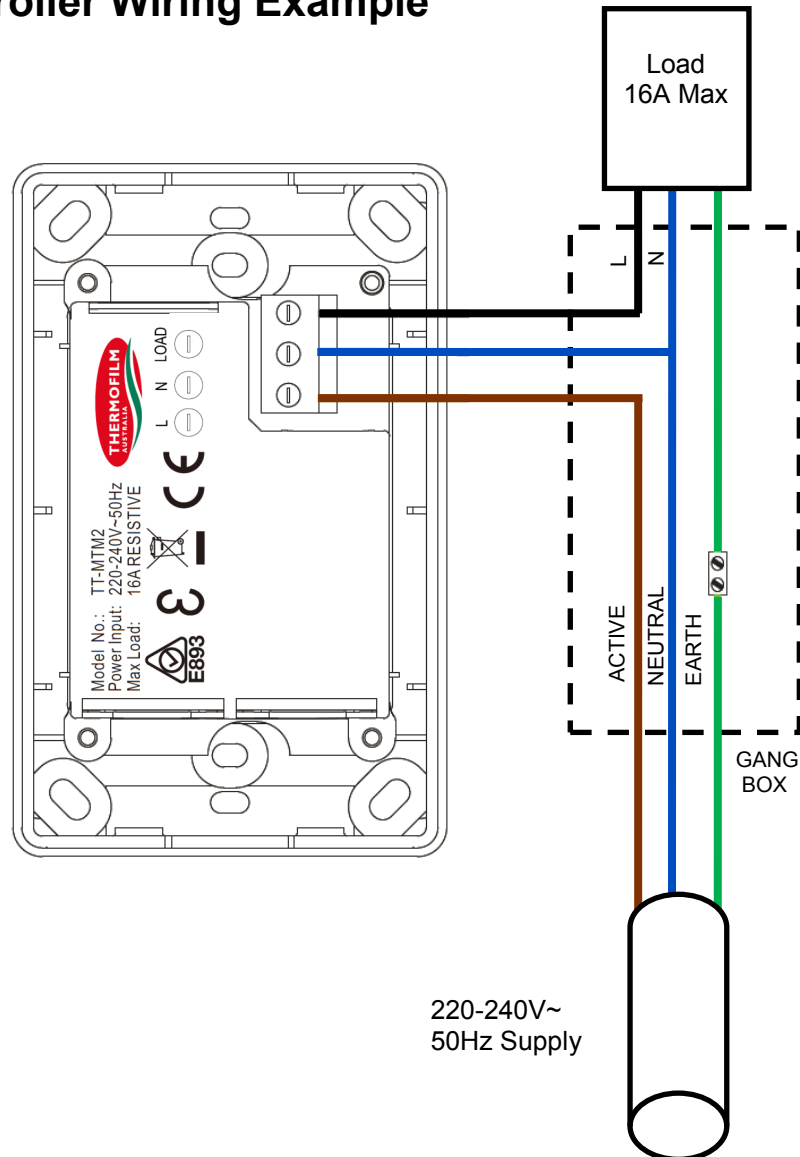

The TT-MTM2 controller requires sufficient air circulation in order to provide continuous operation on the high power load setting. The vents must remain clear at all times; never block or cover the vents.

An ideal controller installation will provide significant space around the back of the controller. Installing into restricted spaces, such as brick walls, may result in overheating if adequate ventilation is not provided.



Heater wiring schematic diagrams

It is recommended to install an ON/OFF isolation switch before the controller and ensure the unit is turned OFF after use.

Multiple heaters can be operated using a single controller, however the maximum current rating of 16A must not be exceeded. For direct wiring to the controller, the maximum is generally one heater unit unless the combined maximum current is less than 16A. For example, 2x THH1800A can be connected directly to the controller.

Below are example circuits indicating potential installation configurations. Always check with your electrician and ensure all wiring is in accordance with local regulations.

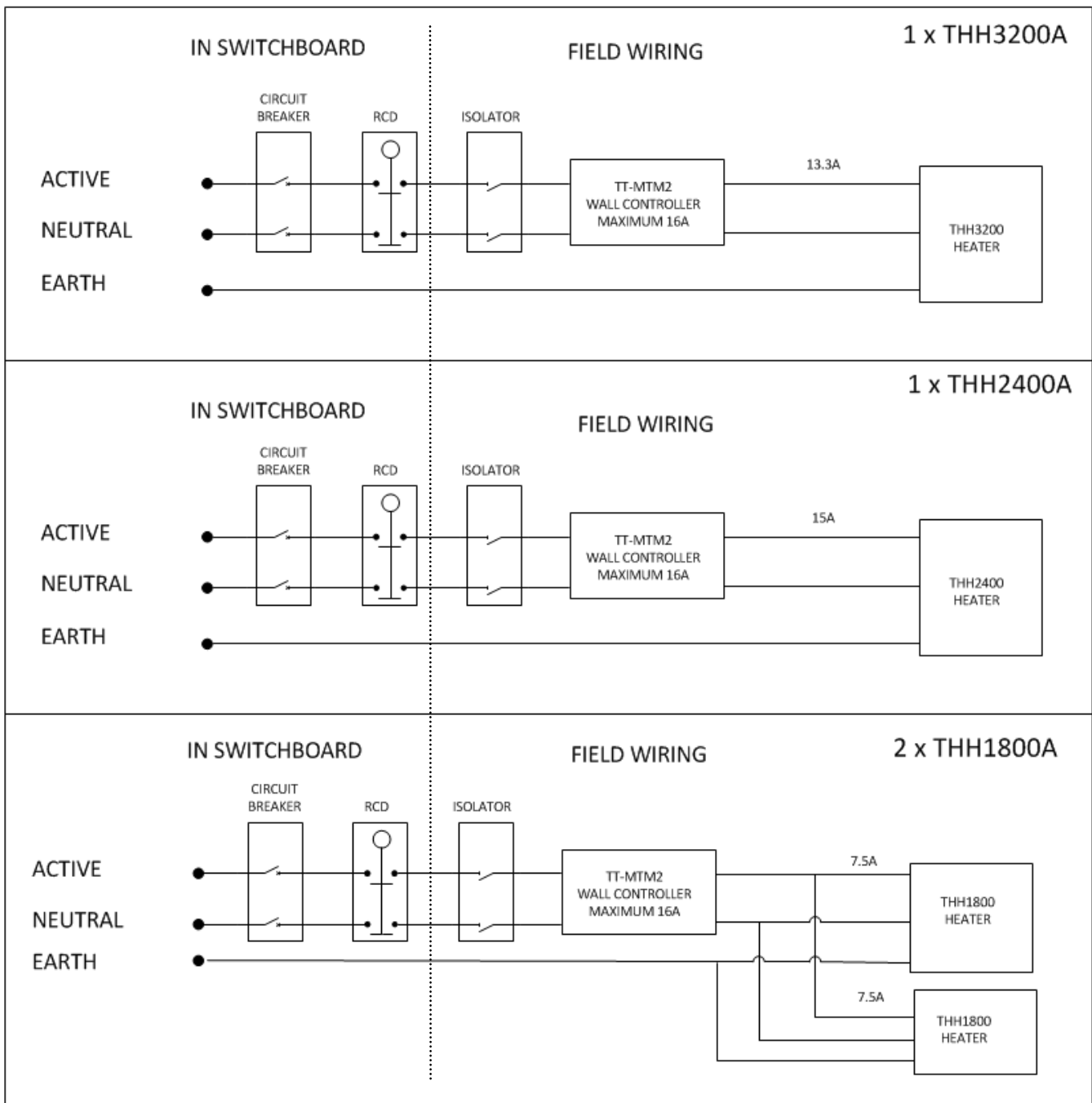



Heater wiring schematic diagram with relays

When more heating units need to be connected from the same controller a relay will be required. It is recommended that you talk to your electrician for more detail.

Below is an example circuit indicating one potential installation configuration. Always check with your electrician and ensure all wiring is in accordance with local regulations.

Note to electrician: The controller modulates the heat output using a “timed on / timed off” function. The controller does not modulate the voltage output. A relay is therefore suitable for this application.

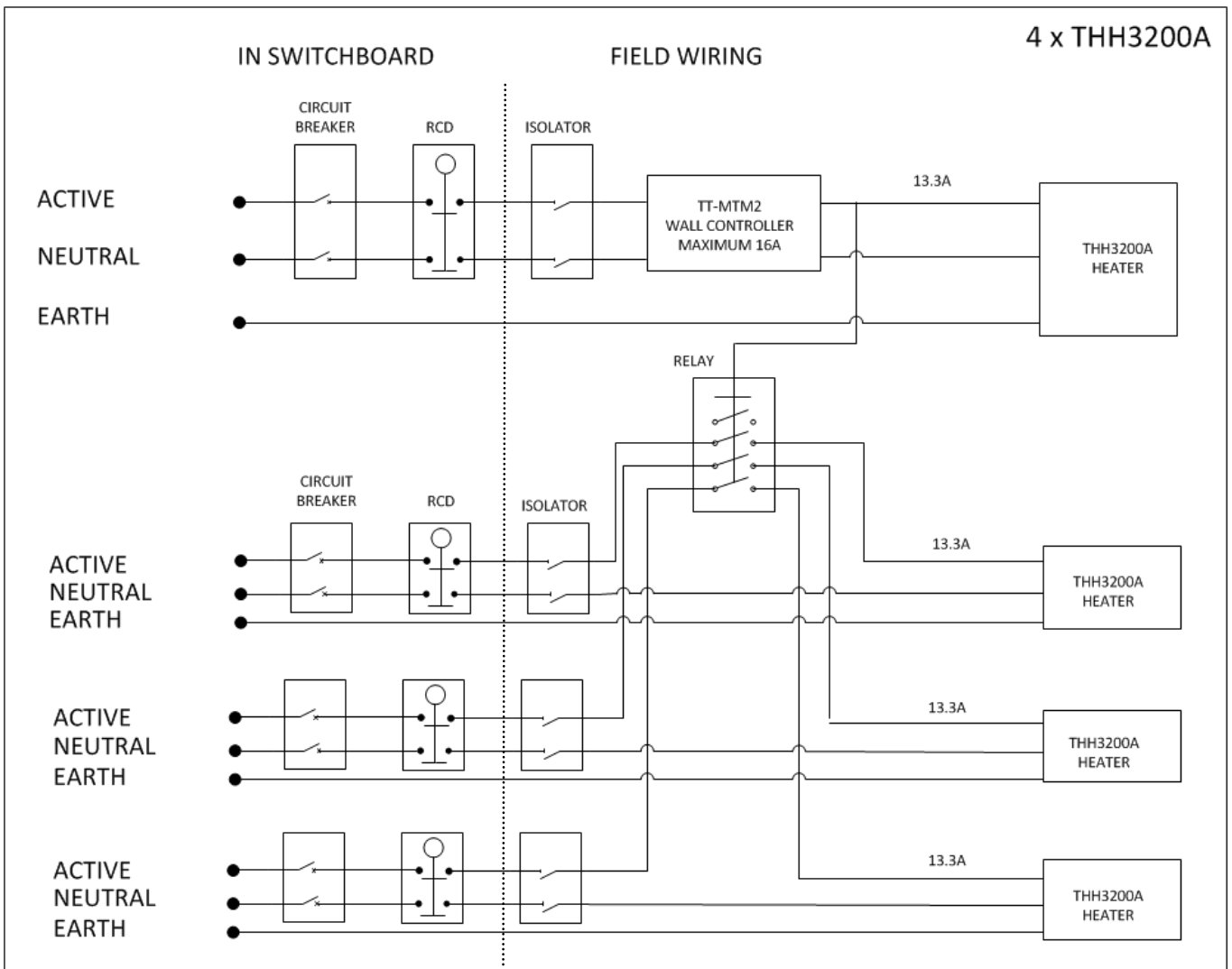



Warranty Terms & Conditions

The below Warranty Terms and Conditions apply for **New Zealand and Australia only**. For international warranty please refer to international warranty terms and conditions.

Thermofilm warrants to the original owner that HEATSTRIP® products will be free from defects in materials and workmanship for a period of 12 months from the date of purchase in accordance with the following warranty terms and conditions.

Provision of this warranty is subject to:

- The HEATSTRIP® products must be installed in accordance with the Installation Instructions and relevant electrical standards and codes.
- The HEATSTRIP® products must be maintained and cleaned according to instructions detailed in the Installation Manual.
- There is no warranty expressed or implied with regard to capacity requirements. The selection of the unit or units depends entirely upon the system design and capacities as determined by the purchaser.
- The customer has not repaired, opened or altered the product in any unauthorised manner.
- This warranty excludes damage to the product or components arising from circumstances outside the control of Thermofilm, including, but not limited to, where the product is not used for intended purpose; where the product has been rectified in any way; incorrect installation; incorrect power supply; damaged caused during delivery; misapplication, misuse, abuse, vandalism, lack of maintenance or accident.
- Thermofilm's obligations under this warranty are limited to repair or replacement at Thermofilm's factory of any components of the product which Thermofilm identifies to its satisfaction to be defective.
- Transportation charges involved in return of the product to the Thermofilm factory (or any other location authorised in writing by Thermofilm) is the sole responsibility of the customer.
- All products are inspected and tested before despatch and are at the risk of the purchaser after the shipment from the Thermofilm factory, if not delivered by Thermofilm to destination.
- No products or components will be supplied in advance of an examination of the faulty product or components by Thermofilm or an authorized representative of Thermofilm.
- Thermofilm does not participate in any site related costs or labour expenses incidental to replacement of parts, repairing, removing, installing, servicing, transportation or handling of parts to complete products, and assumes no liability on parts repaired or replaced without written authorisation. Thermofilm shall not be liable for any default or delay in performance of its warranty obligations caused by any circumstances beyond its control, including, but not limited to, judicial or government restrictions, strikes, fires, floods, abnormal weather conditions, delayed supply of components.

Should products be determined as damaged on arrival, immediately notify the transport company of the condition and have them noted on the freight documents. If damage is discovered after unpacking, demand immediate inspection by the transportation company and insist that a record of the damage is made on the freight documentation.

The customer warrants using the product in accordance with:

- Any instructions provided to it by Thermofilm from time to time.
- All government and local regulations, including but not limited to all relevant electrical, environmental laws and regulations governing the installation, storage, use, handling and maintenance of the goods.
- All necessary and appropriate precautions and safety measures relating to the installation, storage, use, handling and maintenance of goods.

Our goods come with guarantees that cannot be excluded under the Australian Consumer Law. You are entitled to a replacement or refund for a major failure and for compensation for any other reasonably foreseeable loss or damage. You are also entitled to have the goods repaired or replaced if the goods fail to be of acceptable quality and the failure does not amount to a major failure.

All warranty requests for repairs or replacements must be accompanied by a complete "Warranty Claim Form" available from Thermofilm, together with proof of purchase (and where possible, photos of the installation) and the heater returned to the place of purchase.

In the event of a warranty claim, the goods need to be returned to the distributor/retailer for repair/replacement. Contact
Thermofilm Australia Pty Ltd
17 Johnston Court, Dandenong South, Victoria 3175, Australia
Telephone: (03) 9562 3455,
Email: info@thermofilm.com.au